



INSTALLATION MANUAL AND OPERATING INSTRUCTIONS

Manual P/N SPTSDL-1

SPT SUPER DOME COBB LED DOME LIGHT P/N – SPTSDLB/SPTSDLC 14 volt



SPT SUPERDOME
By Superior Panel Technology

FOREWORD

This manual provides information intended for use by persons who, in accordance with current regulatory requirements, are qualified to install this equipment. If further information is required, please contact:

Superior Panel Technology
340 E. First St. Unit 1576
Tustin, CA 9280

Copyright 2019

REVISION HISTORY

Rev.	Date	Approved	Detail
A	06/10/19	WB	Initial release.
B	04/26/22	WB	Change of Address

TABLE OF CONTENTS

SECTION 1 GENERAL DESCRIPTION

- 1.1 INTRODUCTION
- 1.2 TECHNICAL SPECIFICATIONS
 - 1.2.1 ELECTRICAL ATTRIBUTES
 - 1.2.2 PHYSICAL ATTRIBUTES

SECTION 2 PRE-INSTALLATION CONSID

- 2.1 COOLING
- 2.2 EQUIPMENT LOCATION
- 2.3 ROUTING OF CABLES

SECTION 3 INSTALLATION PROCEDURES

- 3.1 GENERAL INFORMATION
- 3.2 UNPACKING AND INSPECTING
- 3.3 CABLE HARNESS
 - 3.3.1 WIRE GAUGE SELECTION
 - 3.3.2 WIRE ASSIGNMENT INFORMATION
 - 3.3.3 HARNESS VERIFICATION
- 3.4 MOUNTING
- 3.5 INSTALLATION COMPLETION

SECTION 4 CONFORMANCE

- 4.1 CONTINUED AIRWORTHINESS STATEMENT

SECTION 5 WARRANTY

SECTION 1 GENERAL DESCRIPTION

1.1 INTRODUCTION

The SPTSDLB OR SPTSDLC here on out will be referred to as the "SPTSDL". This is the same exact unit with the exception of the color anodizing of the front face plate (B=BLACK, C=CLEAR).

The SPTSDL Is an ultra-bright Dome light that can be used in a variety of aircraft locations: Cabin, Baggage, Door entry, etc. The SPTSDL super dome provides a bright, wide angle, cool-white flood light. A dimmer is highly suggested for use with this light. The recommended dimmer is the Superior Panel Technology dimmer model SPTPWLEDS. This dimmer will provide even, full-range dimming from barely visible to full bright. This dimmer has a built in circuit breaking off switch which allows you to connect directly to a battery with an inline fuse so that you to turn on the light without turning on the master switch (if desired).

1.2 TECHNICAL SPECIFICATIONS

1.2.1 ELECTRICAL ATTRIBUTES

Input Voltage:	14-VDC
Input Power:	4 watts max; .25 amps @ 14 VDC

Table 1.1

1.2.2 PHYSICAL ATTRIBUTES

Weight:	1.41 oz
Dimensions: (not including connector)	2 inches wide X 3.33 inches long X .25 inches thick

SECTION 2 PRE-INSTALLATION CONSIDERATIONS

2.1 COOLING

No external cooling is required. The unit will become warm when in use. This is normal and within operational parameters. No special mounting considerations are required; however, mounting to a metal surface can help dissipate any heat generated and extend the life of the product.

2.2 EQUIPMENT LOCATION

The SPTSDL Super Dome Cobb LED light is designed for mounting flexibility, allowing for installation in the cockpit, cabin, baggage compartment, or under seat lighting. Another great installation location is in gull-wing doors as puddle lights, for example the doors in a Vans RV-10.

2.3 ROUTING OF CABLES

Avoid sharp bends in cabling and routing near aircraft control cables. Avoid close proximity and contact with aircraft structures, avionics equipment or other obstructions that could chafe wires during flight and cause undesirable effects.

SECTION 3 INSTALLATION PROCEDURES

3.1 GENERAL INFORMATION

This section contains interconnect diagrams, mounting dimensions and other information pertaining to the installation of the SPTS DL. After installation of cabling and before installation of the equipment, ensure that power and ground are applied to the proper wire leads as described in the wiring description.

3.2 UNPACKING AND INSPECTING EQUIPMENT

When unpacking this equipment, make a visual inspection for evidence of any damage that may have occurred during shipment. The following parts should be included:

Equipment Provided:

- a. Super Dome Cobb LED Light SPTS DL
- b. Two 6/32 100 degree stainless c/s screws
- c. Two 6/32 nylon locknuts
- e. Pulse width modulation dimmer **(IF ORDERED)** SPTPWMLEDS

Equipment Not Provided:

- a. Cable Harness Wire
- b. Circuit Breaker Recommend 1 amp (14v sys)

3.3 WIRING

Use the appropriate wire gauge size as indicated in table 3.1 below to bring the ground wire to the lamp to connect to the black wire. Bring a second wire from the 14V DC power source (normally the output from SPT's PWM dimmer-yellow screw) and connect to the red wire. Refer to Section 2: Pre-Installation Considerations, for routing precautions.

3.3.1 WIRE GAUGE SELECTION

Use of PTFE, ETFE, TFE, Teflon or Tefzel insulated wire is recommended for aircraft use. The wire harness should utilize 20-22 AWG stranded wire. Refer to table 3.1 below.

Wire Gauge	Wire Length
20 AWG stranded wire	>14 ft
22 AWG stranded wire	<14 ft

TABLE 3.1
Wire Gauge and Length

3.3.2 WIRE ASSIGNMENT INFORMATION

INPUT POWER:

Red wire – Positive DC input +14 VDC power

Black wire – Negative DC input / ground

3.3.3 HARNESS VERIFICATION

WARNING:

Failure to install aircraft power and ground wires in the proper wiring configuration will permanently damage the unit.

Once the cable harness is prepared, prior to connecting the SPTSDL, activate the aircraft power bus and use a multimeter to verify that aircraft power and ground is supplied with appropriate voltage on the proper wire to be connected to the SPTSDL.

3.4 MOUNTING

Prepare the panel cutout using the dimensions on the hole cutout drawing below. It is best practice to first use the aluminum Super Dome frame as a marking guide using a sharpie fine point marker or mechanical pencil to locate where to drill the $\frac{9}{64}$ " holes mounting holes. This is easily preformed by holding the front face of the SuperDome toward the panel to be drilled. Then simply mark the center point between the two mounting holes to locate the center point for the 1.5" holesaw. The depth of the 1.5" hole needs to be at least $\frac{1}{2}$ " for clearance for an electronic component and wires.

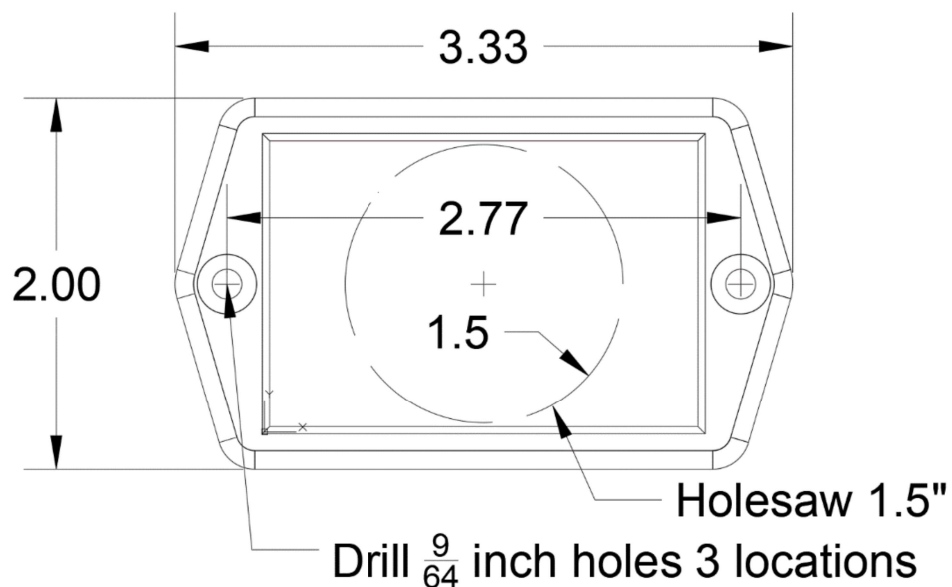

FIGURE 3.2
SPTSDL Outline Drawing

3.5 INSTALLATION COMPLETION

Prior to operating the unit in the aircraft, it is recommended to verify the output and functionality of the unit.

SECTION 4 CONFORMANCE

4.1 CONTINUED AIRWORTHINESS STATEMENT

No periodic scheduled maintenance or calibration is necessary for continued airworthiness of the SPTSDL Super Dome LED Light. If the unit fails to perform to specifications, the unit must be removed and serviced by Superior Panel Technology.

SECTION 5 WARRANTY

5.1 WARRANTY

SPT will repair or replace at its expense and at its option any SPT Super Dome light manufactured by SPT which in the normal use has proven to be defective in workmanship or material, provided that the customer returns the product prepaid to SPT along with proof of purchase of the product within a 2 year period and provides SPT with reasonable opportunity to verify the alleged defect by inspection. SPT will not be responsible for any asserted defect which has resulted from misuse, abuse or over stressing above published specifications. SPT will under no circumstances be liable for incidental or consequential damages resulting from the defective products. This warranty is SPT's sole warranty and sets forth the customer's exclusive remedy with respect to defective products. All other warranties, expressed or implied, whether of merchantability, fitness for purpose, or otherwise, are expressly disclaimed by SPT.